

# QUICK START GUIDE

## QuickMatriX - Ref. QMX150



Thank you for choosing **Analog Way** and the **QuickMatriX**. By following these simple steps, you will be able to set up and use your powerful 8x2 Seamless Matrix Scaler based on **Analog Way's** Midra™ platform within minutes. Discover the **QuickMatriX** capabilities and intuitive interface while configuring your first show and unleash your creativity for a new experience in show and event management.

### WHAT'S IN THE BOX

- 1 x **QuickMatriX (QMX150)**
- 1 x Power supply cord
- 1 x Ethernet cross cable (for device update)
- 1 x Remote Control Software (RCS<sup>2</sup>)\*
- 1 x Set of 6 audio 5-pin screw terminals
- 1 x Front Rack Ears (the parts are stowed in the packaging foam)
- 1 x User Manual (PDF)\*
- 1 x Quick Start guide\*

\* User manual, quick start guide and the RCS<sup>2</sup> are available on [www.analogway.com](http://www.analogway.com)

### CAUTION!

If required, front handles of the device can be dismantled, but with caution. The original screws removed must not be reintroduced to their location without handles in place. Substantial damages can occur, including risk of electric shock from the mains voltage. Only M4x12mm screws can be used. (They are supplied with the unit.)



Go on our website to register your product(s) and be notified about new firmware versions: <http://bit.ly/AW-Register>

### QUICK INSTALL AND SETUP

#### Getting started:

You may wish to reset the unit to factory settings to get started. Go to: **Menu > Control > Reset/erase > Default Values > Yes**

**1.** Select the Output resolution that matches the native resolution of your display. You will next be prompted to choose enable follow mode if desired and output rate.

**Menu > Output 1 > Output format > 1920x1080 > Internal Ref > 60 Hz**

Do the same for Output #2.

**2.** Inputs can be configured automatically using the *Auto-Set All* function. **Menu > Inputs > AutoSet All > Yes**  
It will scan each input and detect the sync type that is plugged in. You can still do an Autoset or manual setup per input.

The **QuickMatriX** has 3 layers available called: **LAYER A**, **QUICK FRAME** and **1 KEYED LAYER** available with controllers.

**3.** To display a source, select the output, select a source (it will blink). Press **TAKE** to transition your source from Preview to Program output.

There will always be an output selected and a source selected (blinking).

**4.** To display a keyed Titling layer, you will need the RK-350 or ORC50, select a layer, select a source into it, apply a keying effect on the the source to be able to see it on your Program output.

**5.** To clear the keyed layer or any other layer, select **BLACK** and select the output. Press **TAKE**.

**TIP:** If you would like the Program and Preview to toggle/flipflop during each TAKE, enable this feature by going to **Menu > Control > Preset Toggle**

Once enabled, everything on the old Program output will become the new Preview after each TAKE. See the next page which describes the button lighting color code and other front panel features.

#### QuickMatriX can be used to display:

- Sources seamlessly switched in the **LAYER A** of each outputs. (Only 1 layer)

- **1 Titling keyed layer** over the **LAYER A**. (No more seamless effects)

**IMPORTANT:** Simply selecting a menu item will not set it to that value. Be sure to press the **ENTER** button when setting the menu items.



# QUICKMATRIX - REF. QMX150 / FRONT & REAR PANELS DESCRIPTION

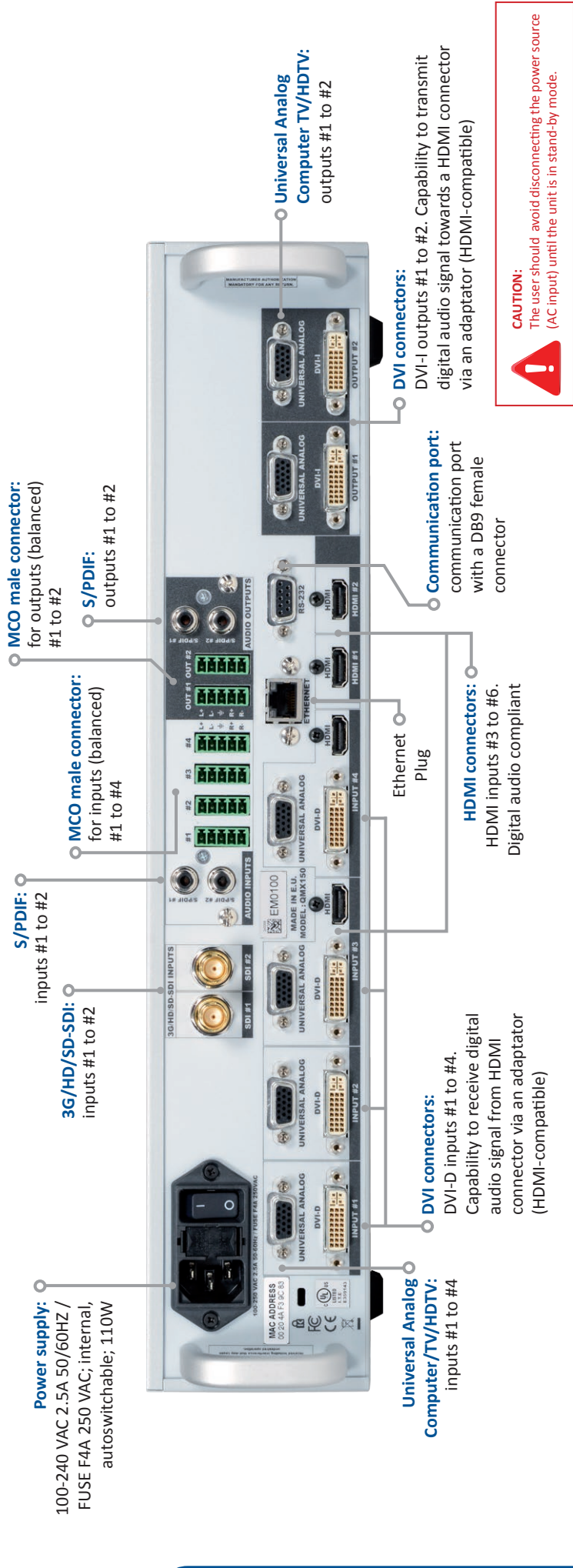
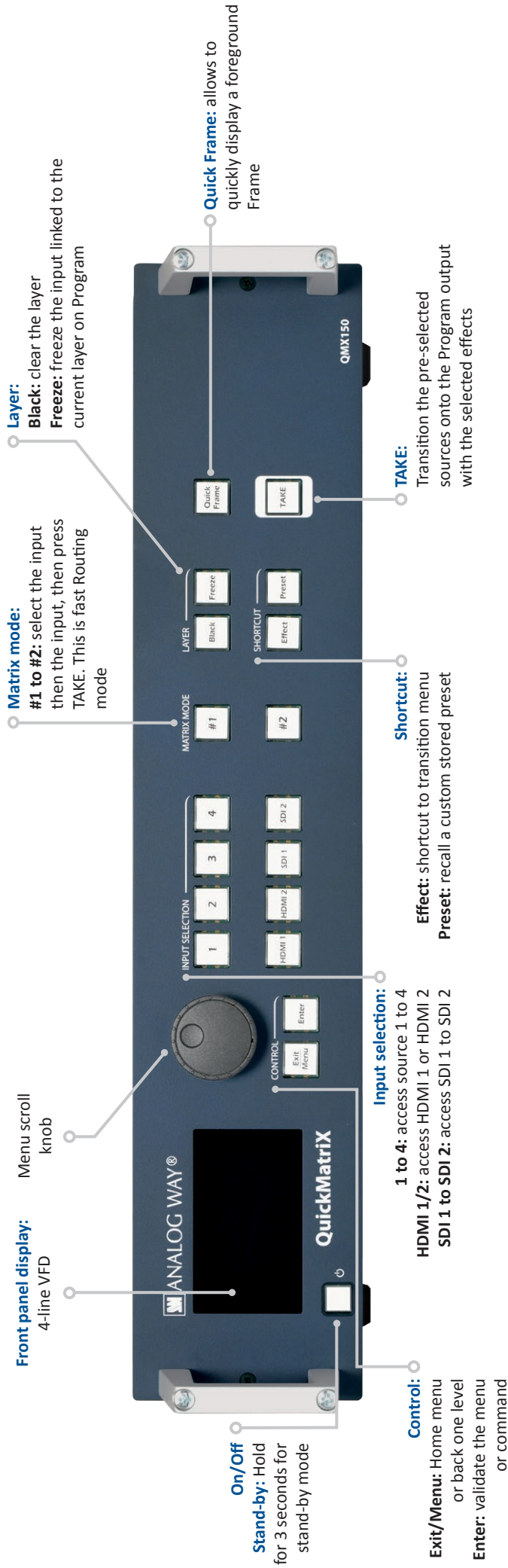

# OPERATION OVERVIEW

## BUTTON COLOR USAGE

- Solid red:**  #1 = Source is on the Program output  
#2 = Freeze enable
- Solid green:**  #1 = Source is on Preview  
#2 = Function available for modification  
#3 = Current output on Matrix mode
- Blinking red:**  Layer/source selected or is currently active on the Program output
- Blinking green:**  Layer/source selected or is not currently active on the Program output

## OUTPUT SETUP

- 1- Press the **EXIT/MENU** button from the Home menu (all functions must be confirmed by the **ENTER** button)
- 2- Select **Output**
- 3- Select **Output format** and then the **Output rate**
- 4- On Format line, select the display's native resolution
- 5- Control or adjust your display device (Monitor or Video Projector)
- 6- If necessary, select **Test Pattern** in the Output menu.

## INPUT SETUP

- 1- Press the **EXIT/MENU** button from the Home menu (all functions must be confirmed by the Enter button)
- 2- Press **Input** and **Autoset ALL**
- 3- If the acquisition is successful the source appears on Preview.
- 4- If the acquisition has failed, check all connections and perform a manual setup
- 5- For a comprehensive Input Setup, please refer to user's Manual
- 6- For a manual input setup, press the **EXIT/MENU** button:
  - a) Press **Input**,
  - b) Select the right input from Input #1 up to SDI #2, then
  - c) Select **Active plug**,
  - d) Select **Type** and choose the input type.

**NOTE:** To adjust layer Size or Pos, use the Layer Menus. To adjust Blanking, use the Auto Centering or Blanking adjustments in the Image menu.

## WORKING IN MATRIX MODE

- 1- Select an **input**.
- 2- Select an **output**.
- 3- Select an **EFFECT** (open/close)
- 4- Press **TAKE** to view the result on the Program

## HOME MENU

- **Output 1:** select to set the output types and resolutions of Output #1
- **Output 2:** select to set the output types and resolutions of Output #2
- **Input:** select to configure the 8 individual input types and resolutions
- **Preset:** select to store and use presets
- **Image:** select to change source image settings of an input
- **Keying/Titling:** select to access keying and titling controls and parameters when video layer is selected
- **Screen:** setup your background color and your Quick Frame
- **Layer:** select to adjust layer size, position, border, transparency or transitions
- **Frames:** select to store (record), use and manage logos and frames into the Quick-Matrix
- **Audio:** select to access all audio input and output parameters
- **Control:** select to access device software information, LAN settings, reset factory settings, amongst other user oriented functions (see next page)

## AUDIO INPUT/OUTPUT CONNECTIONS

### MCO male connectors

Inputs #1 to #4: balanced & unbalanced connection

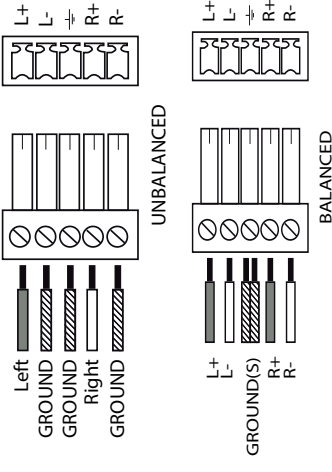

- Inputs #1 & #2: DVI embedded audio HDMI
- Inputs #3 & #4: DVI and HDMI embedded audio HDMI
- Inputs SPDIF #1 and #2: digital audio inputs
- Inputs HDMI #1 and #2: embedded audio HDMI
- Inputs SDI #1 to #2: embedded audio SDI
- Outputs #1 and #2: balanced & unbalanced connection
- Outputs SPDIF #1 and #2: digital audio outputs

## HOW TO DO AN AUTOTAKE?



The Autotake function performs a TAKE automatically each time an input is selected.

## HOW TO RECORD & DISPLAY A QUICK FRAME?



The [Empty] term appears next to all unused slots

**QUICK FRAME:** full and individual frame that can be displayed on top of every layer.

It is possible to store up to 8 frames in the device non volatile memory.

- Select **RECORD FRAMES** in the frames menu.

- A white rectangle will appear on your Program display, indicating the frame which will be caught and saved. (The Frame can be captured in Preview too.)

- To select the Quick frame, please go into the **SCREEN** menu, select **QUICK FRAME** menu and then choose a Frame slot. The selected frame will be your **QUICK FRAME**.

Now to display it, simply press the front panel button **QUICK FRAME**. It becomes solid RED.

- To remove the **QUICK FRAME**, press the **QUICK FRAME** button on the front panel. It becomes solid green.

**TIP:** a long press on the **BLACK** button will clear all layers on Preview. Press **TAKE** to view your Program display turn to black.

## HOW TO DISABLE THE HDCP ENCRYPTION?

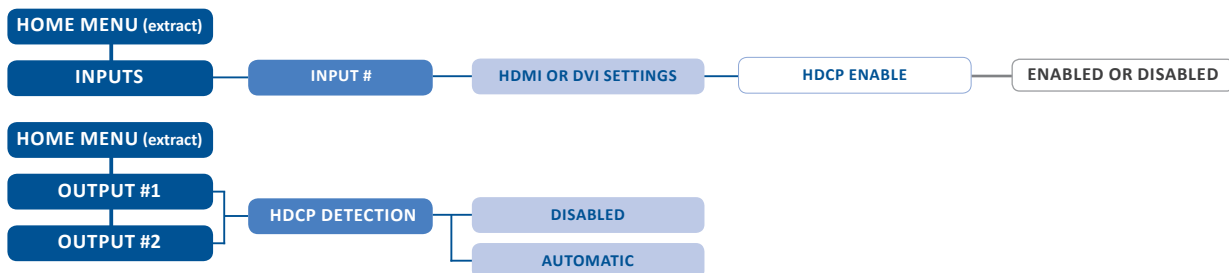

The HDCP Encryption can be disabled on HDMI/DVI inputs or/and Program Output #1 / Program Output #2. This can be useful when you have a computer which is detecting the HDCP compliance of your switcher and protecting the content by encrypting the signal from this computer. This feature will disable the HDCP compliance on this specific HDMI/DVI input only.

If you want to use HDCP content from your sources, be sure to use only HDCP compliant screens or projector. If it's not the case, the output image could be disabled.

Screen will go to black without displaying the HDCP input image, or partially layer out on HDCP content.

The output status can provide you all information about the output in real time. This feature is particularly useful when HDCP is used with long cable to be sure the communication is well handled.

## HOW TO USE THE AUTO-LOCK FUNCTION?



**AUTO-LOCK** allows to select an input only if a signal is valid.

## WARRANTY AND SERVICE

This **Analog Way** product has a 3 year warranty on parts and labor, back to factory. This warranty does not include faults resulting from user negligence, special modifications, electrical surges, abuse (drop/crush), and/or other unusual damage. In the unlikely event of a malfunction, please contact your local **Analog Way** office for service.

## GOING FURTHER WITH THE QUICKMATRIX

For complete details and operations procedures, please refer to the **QuickMatrix** User's Manual and our website for further information: [www.analogway.com](http://www.analogway.com)